

# Vandercook Manual

*Operation — Maintenance*  
*Parts List*

MODEL NO. 4

SERIAL NO. \_\_\_\_\_

Always be sure to give both the above Model and Serial Numbers when ordering parts or requesting information about this machine.



**VANDERCOOK & SONS, INC.**

*Eastern Sales and Service*  
205 W. 34th St., New York, N.Y. 10001  
Telephone BRyant 9-6270

*Main Office, Plant and Technical Center*  
3601 West Touhy Avenue Chicago, Illinois 60645  
Telephone ROgers Park 1-2100

*Western Sales and Service*  
3156 Wilshire Blvd., Los Angeles, Calif. 90005  
Telephone DUmkirk 8-9931

## DIRECTIONS

### VANDERCOOK 4 PROOF PRESS

When Requesting Information Or Ordering Parts, Always Give Serial Number

#### INDEX TO INSTRUCTIONS

A - Level Press  
B - Clean Press  
C - Lubrication  
D - Washup Press  
E - Repacking Cylinder

F - Set Form Rollers  
G - Operation  
H - Adjust Ink Drum Chain  
J - Adjust Motor Belt

#### CAUTION

Before connecting motor, be sure to check current specifications on motor plate. Ink Drum should run counter-clockwise, looking from the operator's side of the Press.

#### A - LEVEL PRESS

Place a spirit level on the bed and level by adjusting screws, which are in the legs of the machine.

#### B - CLEAN PRESS

It is essential that bed and cylinder bearers are kept clean. After cleaning, wipe with an oily rag. Do not allow dirt to accumulate on bed. A clean bed, bed bearers and cylinder bearers will assure a true impression of type or plates. Keep bottoms of cylinder gears and bed racks free from dirt and paper dust.

#### C - LUBRICATION

##### OIL ONCE A WEEK

Fill all oil holes and cups with S. A. E. 20 Motor Oil. Oil gripper stems when grippers are open with a fine oil (3 in 1 or equivalent). Lubricate vibrator worm on form roller carriage with vaseline.

##### INK DRUM SPEED REDUCER MOTOR

See Instructions on Motor Tags.

## DIRECTIONS

### VANDERCOOK 4 PROOF PRESS

When Requesting Information Or Ordering Parts, Always Give Serial Number

#### INDEX TO INSTRUCTIONS

- |                        |                           |
|------------------------|---------------------------|
| A - Level Press        | F - Set Form Rollers      |
| B - Clean Press        | G - Operation             |
| C - Lubrication        | H - Adjust Ink Drum Chain |
| D - Washup Press       | J - Adjust Motor Belt     |
| E - Repacking Cylinder |                           |

#### CAUTION

Before connecting motor, be sure to check current specifications on motor plate. Ink drum should run counter clockwise, looking from the operator's side of the Press.

#### A - LEVEL PRESS

Place a spirit level on the bed and level by adjusting screws, which are in the legs of the machine.

#### B - CLEAN PRESS

It is essential that bed and cylinder bearers are kept clean. After cleaning, wipe with an oily rag. Do not allow dirt to accumulate on bed. A clean bed, bed bearers and cylinder bearers will assure a true impression of type or plates. Keep bottoms of cylinder gears and bed racks free from dirt and paper dust.

#### C - LUBRICATION

##### OIL ONCE A WEEK

Fill all oil holes and cups with S.A.E. 20 Motor Oil. Oil gripper stems when grippers are open with a fine oil (3 in 1 or equivalent). Lubricate vibrator worm on form roller carriage with vaseline.

##### MOTOR LUBRICATION

Oil cups are provided at either end of motor bearings on plain bearing motors. These should be filled every month of press operation with S.A.E. 20 Motor Oil. Bearings for ball bearing motors should be repacked once a year.

##### INK DRUM SPEED REDUCER

The oil level in the speed reducer should be checked every month. Add S.A.E. 40 Oil as required, to bring up to proper level.

## DIRECTIONS

### VANDERCOOK 4 PROOF PRESS

When Requesting Information Or Ordering Parts, Always Give Serial Number

#### INDEX TO INSTRUCTIONS

- |                        |                           |
|------------------------|---------------------------|
| A - Level Press        | F - Set Form Rollers      |
| B - Clean Press        | G - Operation             |
| C - Lubrication        | H - Adjust Ink Drum Chain |
| D - Washup Press       | J - Adjust Motor Belt     |
| E - Repacking Cylinder |                           |

#### CAUTION

Before connecting motor, be sure to check current specifications on motor plate. Ink Drum should run counter-clockwise, looking from the operator's side of the Press.

#### A - LEVEL PRESS

Place a spirit level on the bed and level by adjusting screws, which are in the legs of the machine.

#### B - CLEAN PRESS

It is essential that bed and cylinder bearers are kept clean. After cleaning, wipe with an oily rag. Do not allow dirt to accumulate on bed. A clean bed, bed bearers and cylinder bearers will assure a true impression of type or plates. Keep bottoms of cylinder gears and bed racks free from dirt and paper dust.

#### C - LUBRICATION

##### OIL ONCE A WEEK

Fill all oil holes and cups with S. A. E. 20 Motor Oil. Oil gripper stems when grippers are open with a fine oil (3 in 1 or equivalent). Lubricate vibrator worm on form roller carriage with vaseline.

##### INK DRUM SPEED REDUCER MOTOR

See Instructions on Motor Tags.

D - WASHUP PRESS

Move cylinder about a foot away from feed board. Raise ink unit lever and remove vibrator and rider frame to end of bed. Wash form rollers in lower carriage with ink unit lever up. This allows easy access to rollers for a thorough washup. Wash vibrator and rider of top frame at end of bed. After washing top and bottom roller units, replace top frame in inking unit and move cylinder to end of bed. With motor running, wash ink drum,

E - REPACKING CYLINDER

The cylinder is ground for .040" packing. It is very important that the correct amount of packing is carried on the cylinder. Incorrect packing is apt to cause misregister, slurs and wrinkles. Over packing will cause the cylinder to print longer than the form and under packing, shorter. The cylinder packing plus the sheet to be printed should be from .002" to .003" over the cylinder bearers. This can be checked with a straight edge. For most work the best cylinder packing consists of all hard manila sheets. Thickness of packing may be adjusted by placing thin sheets next to the cylinder.

To change or adjust packing, move cylinder to center of bed (on trip if there is a form or plate on the bed) so that the reel rod is in the up position. Unlatch reel rod ratchet with wrench provided and loosen drawsheet from reel. With left hand, grasp packing and as cylinder is returned to feed board, lay packing on feed board. If necessary to change the drawsheet, loosen the fillister head screws in the packing clamp gripper bar. Unless overlays are being used only the drawsheet is held by the bar. When moving cylinder to center of bed to secure packing, hold packing in position by smoothing it out with left hand. Be sure packing is tight to cylinder at both sides of gripper edge.

F - SET FORM ROLLERS

Unless otherwise specified, the press is equipped with Synthetic Inking Rollers. These rollers do not change diameter with temperature and humidity as readily as composition rollers, and therefore do not require frequent checking and adjustment. To check the rollers, ink up the inking unit and remove the steel distributors. Move cylinder to the end of bed and insert the Vandercook "Nuway" Roller Setting Gauge between bed and rollers near the end of the roller. If the ink mark on gauge is 1/16" to 3/32" wide at each end of each form roller they are set properly.

To adjust the rollers, loosen both center set screws at each end of carriage. Turning the large flat screws clockwise raises the roller and counter clockwise lowers the roller. After adjusting both rollers to correct height, tighten both set screws. The steel distributors require no adjustment.

#### G - OPERATION

The cylinder will always be on "impression" on its forward travel away from the feed board, unless the impression trip knob is depressed before the cylinder is started. When taking an impression, the cylinder must be moved all the way to the other end of the bed in order that the automatic cylinder trip for the return travel of the cylinder will operate.

When the press is not in use, the motor driven ink drum should always be turned off and the inking system tripped. When the inking system is tripped, the form rollers are free of all contact with the steel distributors. Some operators believe that the ink will dry more slowly if the inking system is kept in operation on the ink drum. Just the reverse is true; the ink will dry much faster if the rollers are kept turning and the entire inking system is subjected to needless wear. Ink should be applied to the vibrator with the inking carriage tripped.

The end sheet guide, nearest the side guide, should always be a trifle in advance of the end guide nearest the operator. This is to prevent misregister because of the sheet dragging against the side guide.

Combination Foot Operated and Automatic Grippers are supplied. For fast operation on single color work, the sheet is allowed to overhang the feed board edge about 1-1/2". The grippers open automatically and take the sheet from the feed board. For close register work, the grippers are opened by the foot pedal and the sheet fed directly to the guides.

Be very careful not to place forms or plates beyond the dead line at the feed board end of the bed. The grippers and end guides will hit any type high material placed beyond the dead line.

#### H - ADJUST INK DRUM CHAIN

After a few weeks of operation, the Drive Chain may stretch a slight amount and rattle against the Guard. If this condition prevails, loosen the cap screws on the Speed Reducer and pull the Reducer back until the chain is taut.

#### J - ADJUST MOTOR BELT

Lower the motor by loosening four nuts on the under side of motor bracket and follow up with tightening four nuts on the top side of motor bracket.

G - OPERATION

The cylinder will always be on "impression" on its forward travel away from the feed board, unless the impression trip knob is depressed before the cylinder is started. When taking an impression, the cylinder must be moved all the way to the other end of the bed in order that the automatic cylinder trip for the return travel of the cylinder will operate.

When the press is not in use, the motor driven ink drum should always be turned off and the inking system tripped. When the inking system is tripped, the form rollers are free of all contact with the steel distributors. Some operators believe that the ink will dry more slowly if the inking system is kept in operation on the ink drum. Just the reverse is true; the ink will dry much faster if the rollers are kept turning and the entire inking system is subjected to needless wear. Ink should be applied to the vibrator with the inking carriage tripped.

The end sheet guide, nearest the side guide, should always be a trifle in advance of the end guide nearest the operator. This is to prevent misregister because of the sheet dragging against the side guide.

Combination Foot Operated and Automatic Grippers are supplied. For fast operation on single color work, the sheet is allowed to overhang the feed board edge about 1-1/2". The grippers open automatically and take the sheet from the feed board. For close register work, the grippers are opened by the foot pedal and the sheet fed directly to the guides.

Be very careful not to place forms or plates beyond the dead line at the feed board end of the bed. The grippers and end guides will hit any type high material placed beyond the dead line.

H - ADJUST INK DRUM CHAIN

After a few weeks of operation, the Drive Chain may stretch a slight amount and rattle against the Guard. If this condition prevails, loosen the cap screws on the Speed Reducer and pull the Reducer back until the chain is taut.

J - ADJUST MOTOR BELT

Lower the motor by loosening four nuts on the under side of motor bracket and follow up with tightening four nuts on the top side of motor bracket.

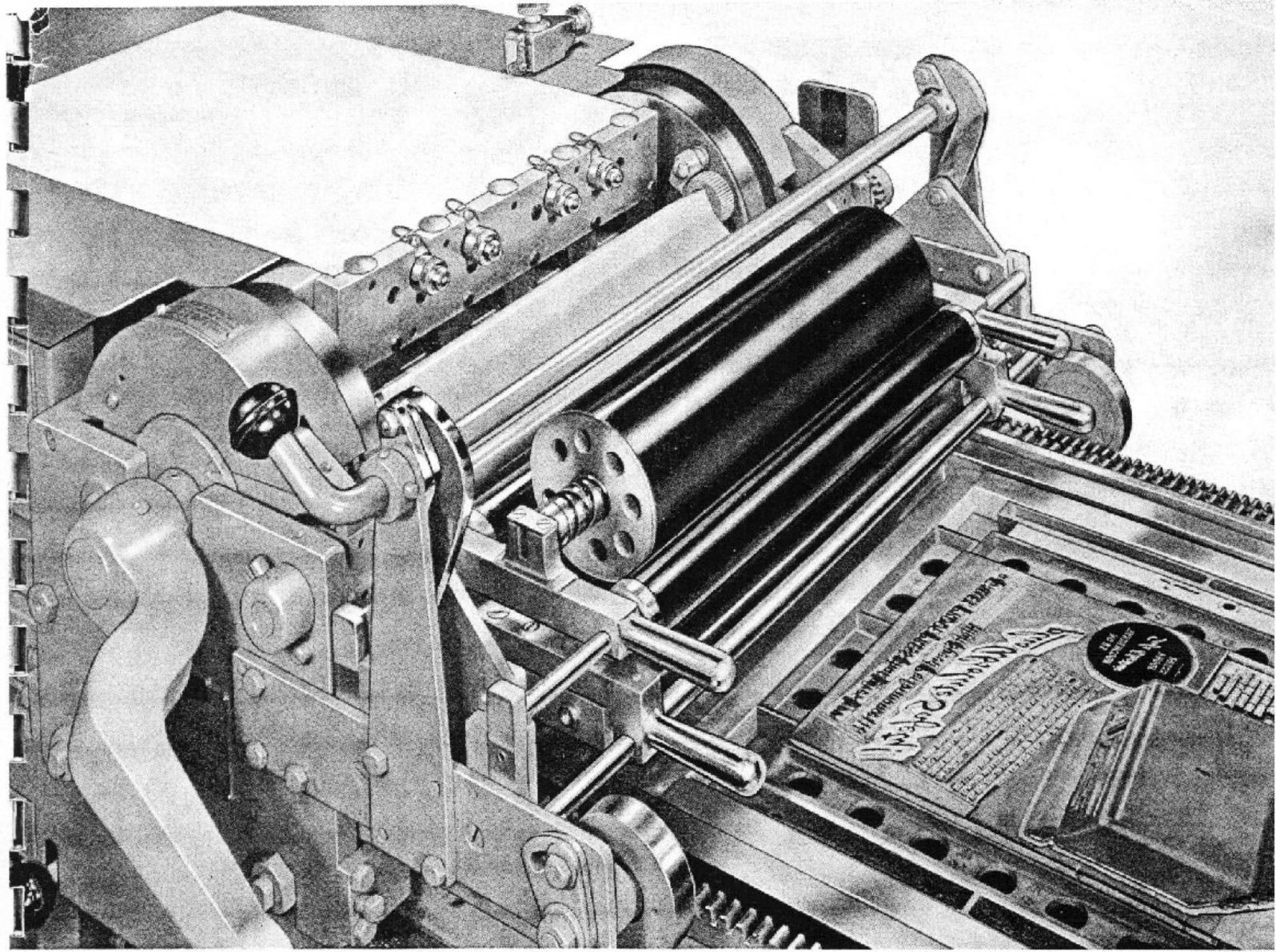

**Vandercook**

**Proof Press**

---



# Vandercook 4 PROOF PRESS

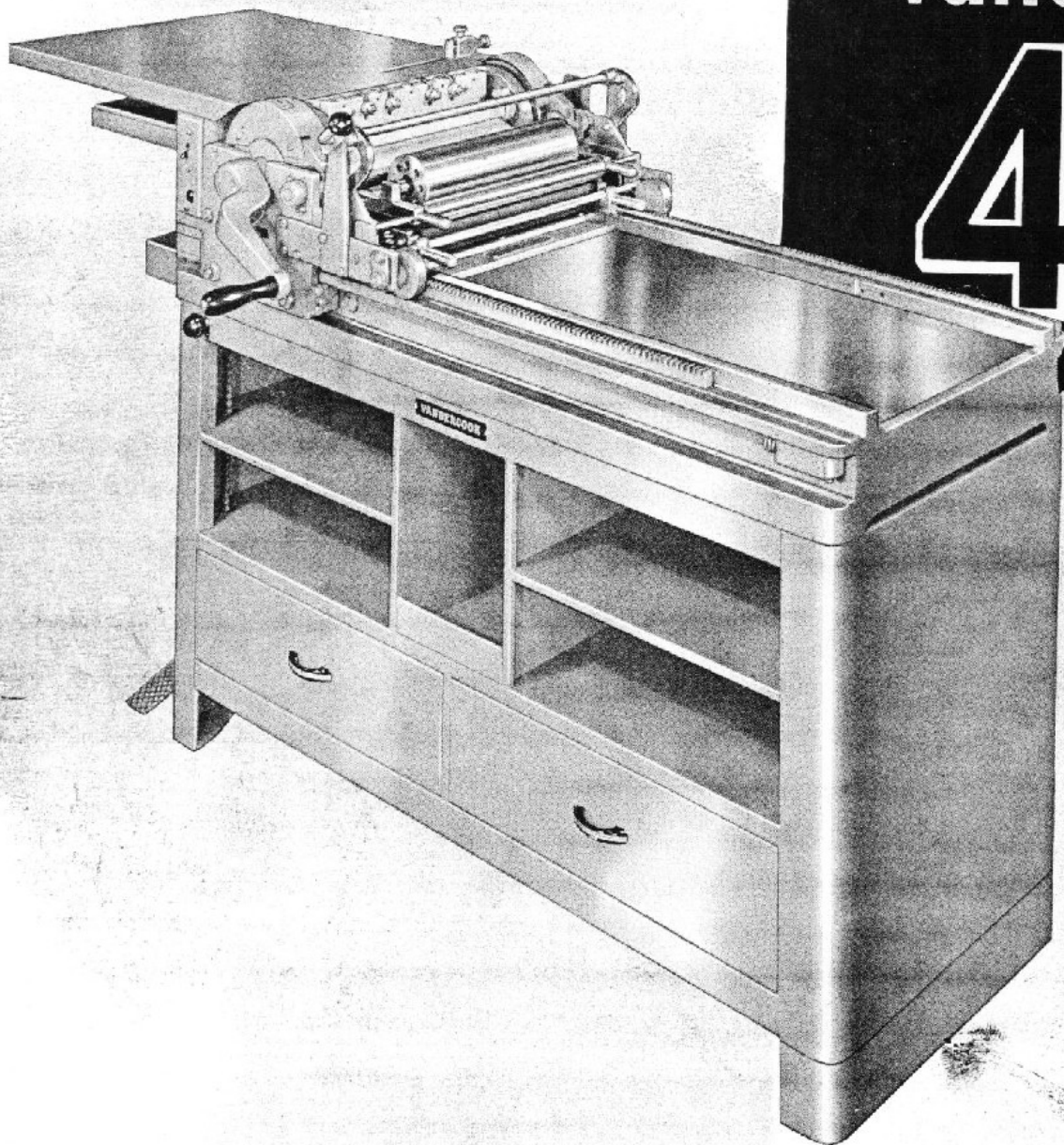

*Micrometer Front and Side Sheet Guides plus Combination Foot Operated and Automatic Cylinder Grippers insure register and permit fast operation.*

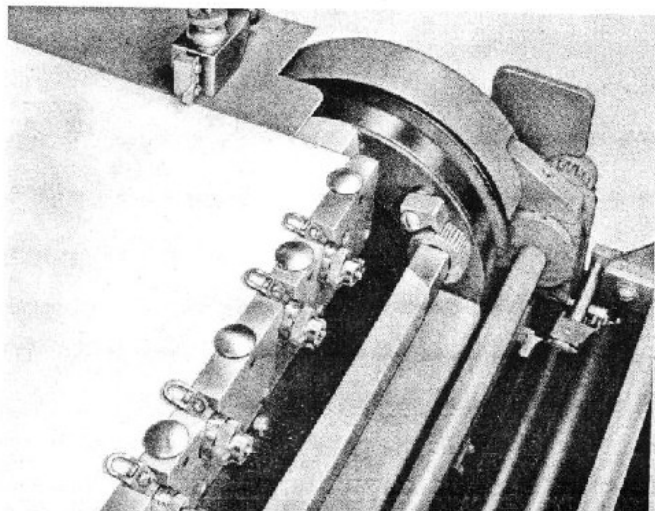

*Two spring steel sheet holders are provided on the Vandercook 4 to prevent wrinkling and buckling of the sheets. They also help to maintain register when proving color.*

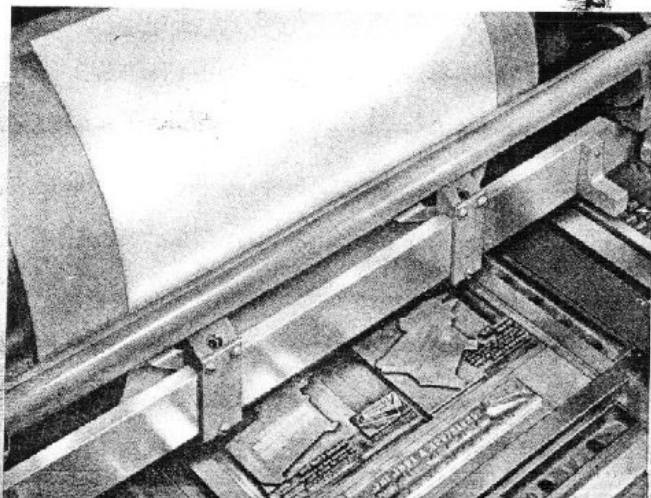

Optional

This is the machine so widely used throughout the world by printers, typesetters, lithographers and gravure plants for making their reproduction proofs. It is also used by ink and paper manufacturers for laboratory purposes, and throughout the graphic arts industry, generally, for the economical production of extra fine proofs. The *Vandercook 4* has numerous features which not only simplify its operation, but insure a consistent high quality of proofs. These include power ink distribution, changeable inking unit, micrometer sheet guides, combination foot operated and automatic grippers.

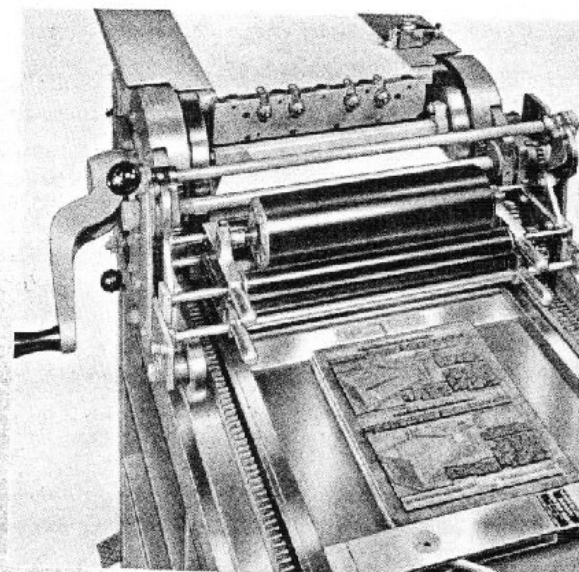

While cylinder is at the feed board and in position for feeding a sheet, the motor driven ink drum turns entire inking unit.

**ions** Bed Size 15" x 35" . . . Maximum Sheet 14 $\frac{3}{4}$ " x 20" . . . Maximum Form 14" x 18" . . . Floor Space 2'2" x 6'6" . . . Net Weight 1100 Lbs. . . . Crated Shipping Weight 1450 Lbs. . . . Finished in machine tool gray.

**ard  
nent** Combination Automatic and Foot Operated Cylinder Grippers . . . Micrometer Sheet Guides . . . Cylinder Trip . . . Steel Cabinet with Drawers . . . Traveling Sheet Delivery Tray . . .  $\frac{1}{4}$  h.p. AC or DC Motor for driving Inking Unit . . . Synthetic Inking Rollers . . . Extra Roller Stocks . . . Tympan with all hard packing . . . 12 Extra Die Cut Drawsheets . . . 12 Extra Die Cut Undersheets . . . Head Dead Line Bar . . . Foot Lockup Bar . . . Necessary Tools.

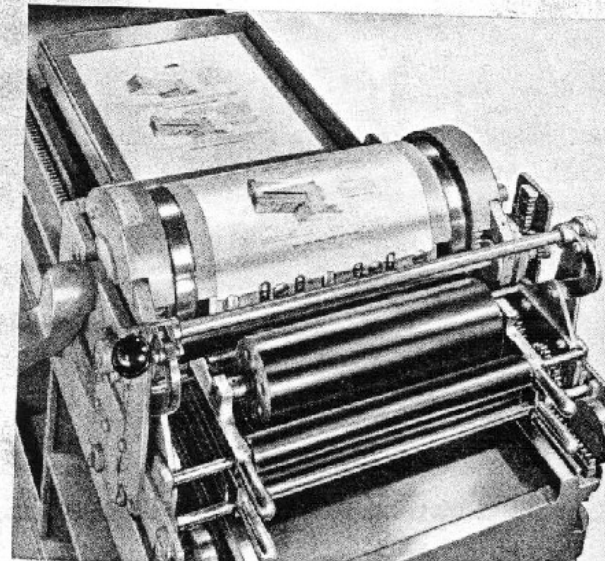

A convenient tray for storing the printed sheets travels with the impression cylinder. This reduces sheet handling to a minimum.

**ment** Vandercook Handy Lockup Bar . . . Vandercook Celluloid Register Punch . . . Split Vibrator and Riders for two-color work . . . Extra Side Guide for two-color work (not adjustable) . . . Special Bed with Galley Thickness Plate (standard No. 4 Bed is machined for use without galleys because better results can be obtained by sliding forms directly to the Bed) . . . Extra Inking Unit with Synthetic Form Rollers, Extra Roller Stocks, complete except for Steel Distributors . . . .025" Rubber Blanket (No. 4 is regularly equipped with .040" Hard Packing which is recommended for best results when proving good material. The Rubber Blanket will help if forms are in bad condition) . . . Patent Base in Drilled Chase.

To facilitate wash-up and changing from one color to another, both the upper and lower frames of the inking unit are easily and quickly removed by the operator.

Showing All-Season Synthetic Form Rollers. Washing up is simple and fast with the Vandercook 4. Entire Inking Unit is removable for washup as shown below.

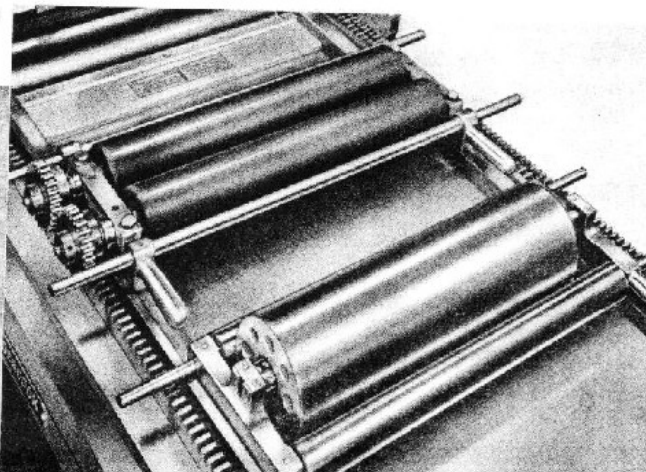
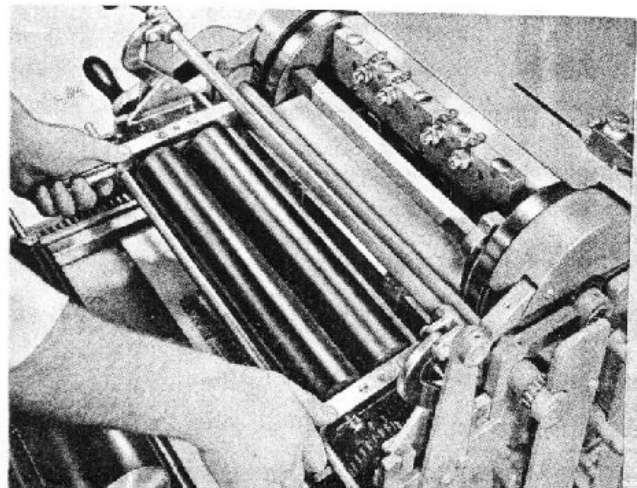

# VANDERCOOK 4

equipped for laboratory testing  
of Inks and Papers

Extra Side Guide

Split Vibrator and Riders

Changeable Inking Units

Patent Base in Drilled Chase

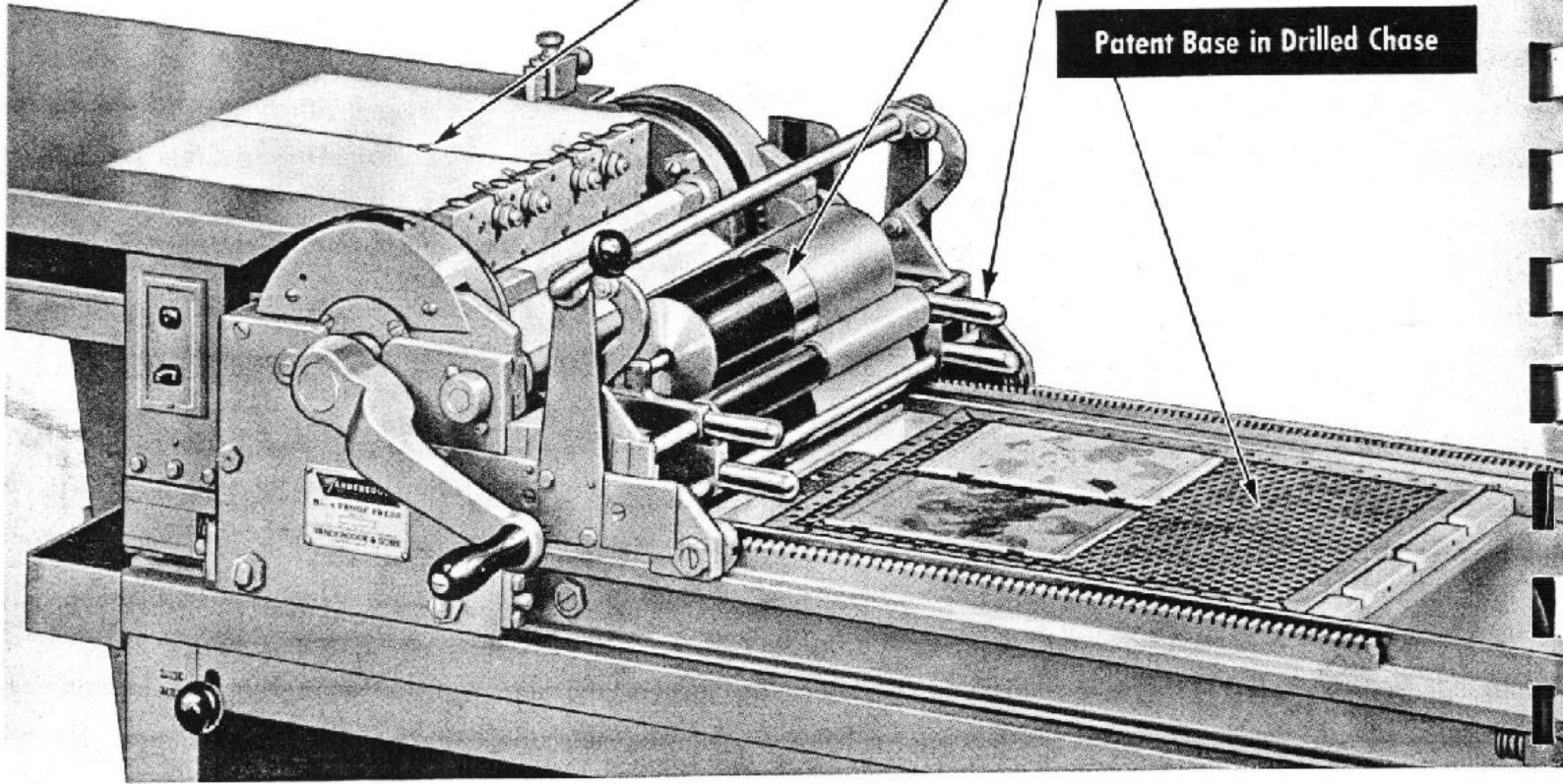

When using the Vandercook 4 for testing inks and papers, it should be equipped with the following additional equipment:

**Split Vibrator and Riders**—for running two colors, or different inks of the same color, at one time.

**Extra Side Guide**—for feeding and registering two sheets. When not in use, can be instantly depressed to the feed board level.

**Changeable Inking Units**—for making quick color changes and changing from one type of roller to another to determine lay of ink and deterioration of rollers.

**Patent Base in Drilled Chase**—for quickly securing unmounted electros.

## Special Laboratory Uses

- 1** Two different papers can be checked for their relative printing qualities on duplicate plates.
- 2** Two inks may be checked for comparison, since they are printed with same impression and at the same speed.
- 3** Drying tests can be made automatically by distributing an amount of ink equal to a printing condition and then tripping the rollers, letting them stand without turning. The ink is checked at intervals for dryness on both composition and steel rollers.
- 4** Ink consumption can be determined by attaching solid plates to the base, and adding ink measured by weight.

**VANDERCOOK**  
PRE-PRESS SYSTEM

## VANDERCOOK & SONS, INC.

PRE-MAKEREADY SPECIALISTS

General Offices, Research Laboratory, Demonstration Room & Factory  
3601 W. Touhy Ave., Chicago 45, Ill. Phone: ROgers Park 1-2100  
Eastern Office & Demonstration Room  
323 E. 44th St., New York 17, N.Y. Phone: MUrray Hill 4-4197  
Western Office  
3156 Wilshire Blvd., Los Angeles 5, Calif. Phone: DUUnkirk 8-9931

PART NO.	PRICE	F.U.	L.U.
AR-18		6579	
ARS-1		"	
BB-58		"	
BRS-13		"	
BS-245		"	
CR-266		"	
F-878		"	
LR-109		"	
LS-24		"	
M-160		"	
MB-112		"	
MR-151		"	
MS-101		"	
NR-221		"	

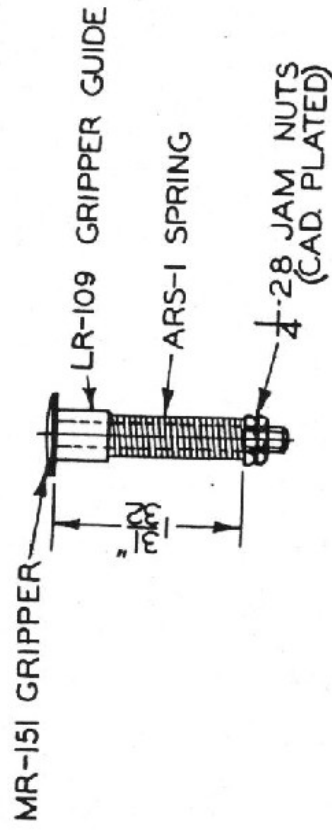
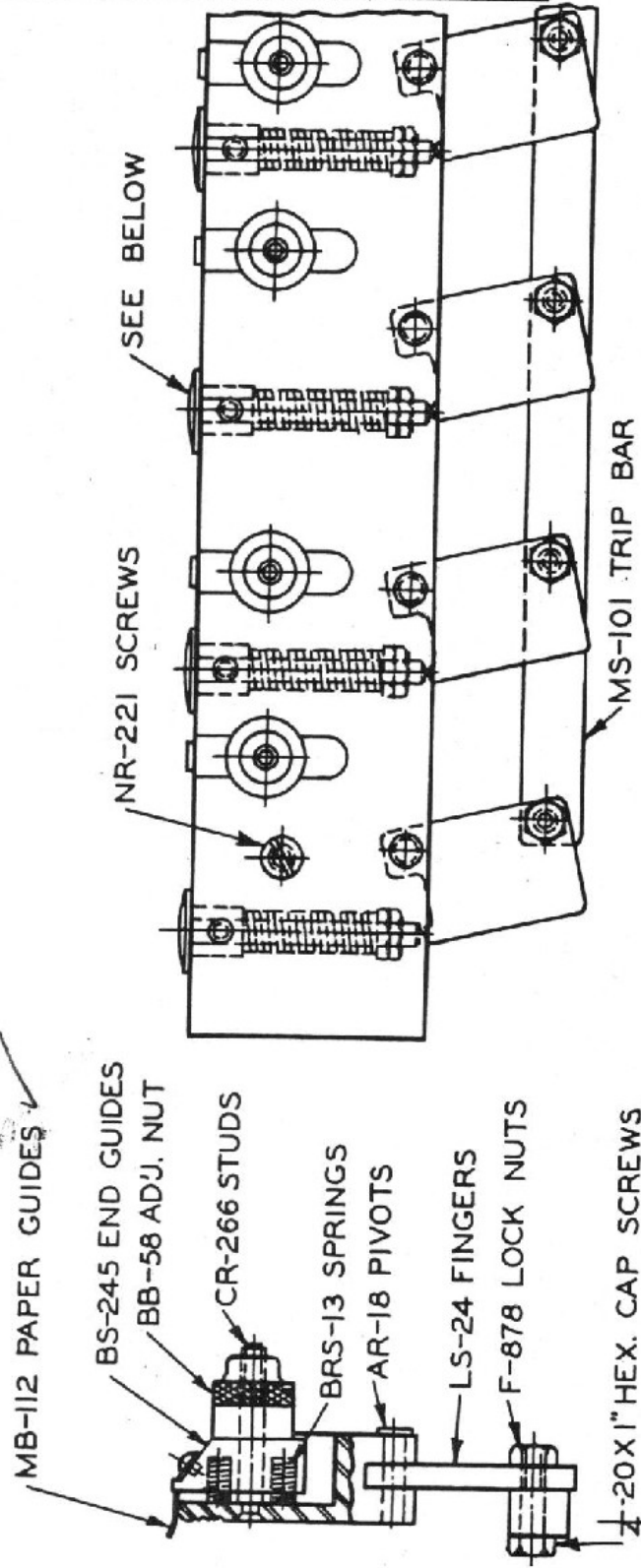

M-160 GRIPPER ASSEMBLY

### LUBRICATION

A FINE MACHINE OIL IS RECOMMENDED FOR ALL MOVING PARTS. LEAVING GRIPPERS OPEN WHEN PRESS IS IDLE WILL ALLOW OIL TO COVER GRIPPER SHANKS THOROUGHLY.

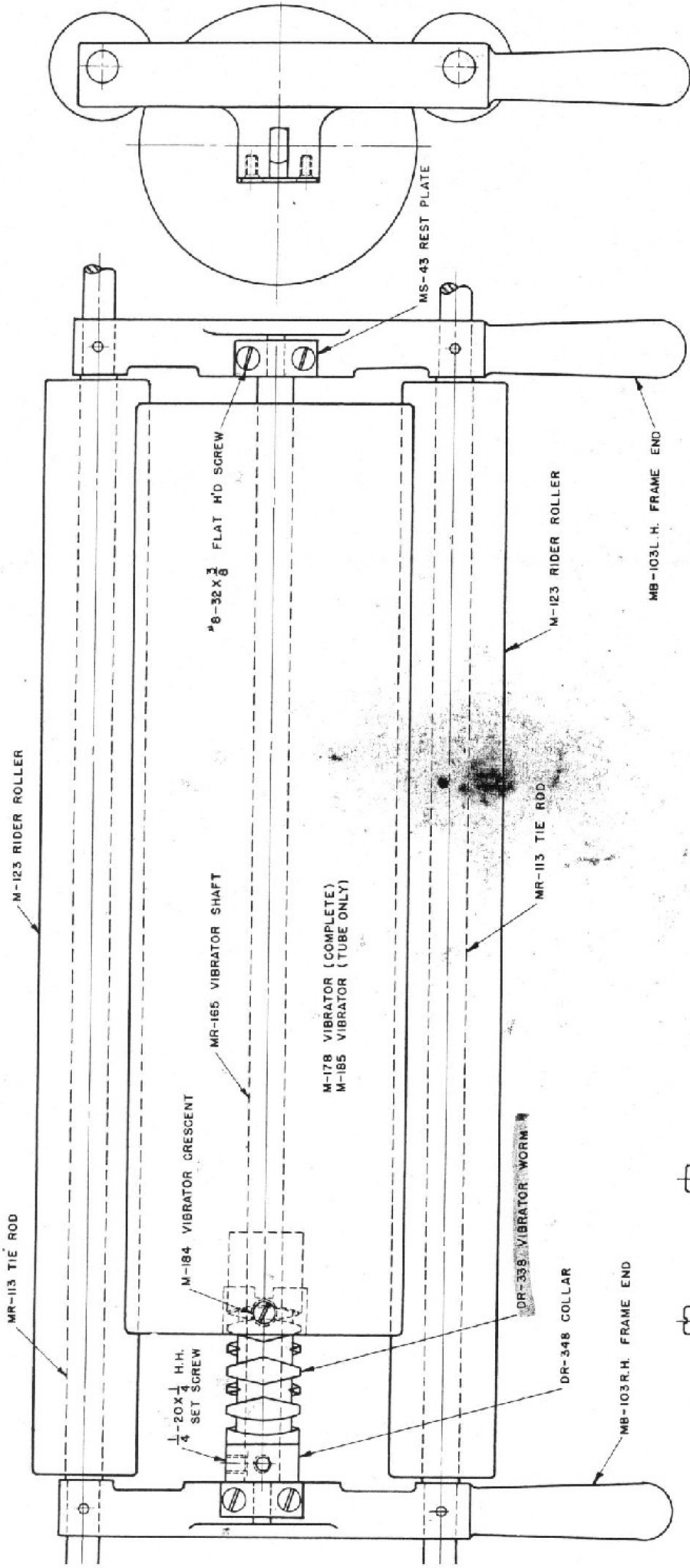

**LUBRICATION**  
 KEEP VIBRATOR WORM THOROUGHLY COVERED WITH VASELINE AT ALL TIMES.

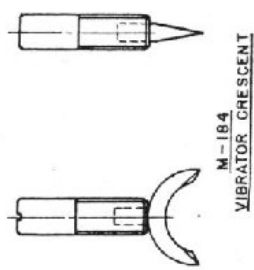

PART NO.	PRICE	F. U.	L. U.
M-123	6369		
M-178			
M-184	6369		
M-185			
MS-103 R	"		
MB-103 L	"		
MR-113	"		
MR-165	"		
MS-43	6369		
DR-338			
DR-348			

M-120 TOP FRAME ASSEMBLY  
 NO. 4 VANDERCOOK PROOF PRESS

IT NO.	TITLE	PRICE	F.U.	L.U.
21	BOTTOM FRAME (COMPLETE WITHOUT CORES & GEARS)	6369		
39	FORM ROLLER (VULCANIZED LINSEED OIL) WITH CORE	"	"	"
39	FORM ROLLER (SYNTHETIC RUBBER) WITH CORE	"	"	"
53	FORM ROLLER GEAR & CLUTCH ASSEMBLY	"	"	"
7	FORM ROLLER BEARING	"	"	"
-102R	BOTTOM FRAME END-R.H.	"	"	"
-102L	BOTTOM FRAME END-L.H.	"	"	"
-22	ADJUSTING SCREWS	"	"	"
-104	FRONT TIE ROD	"	"	"
-105	REAR TIE ROD	"	"	"
-106	FORM ROLLER CORE BARE	"	"	"
-108	CLUTCH BLOCK	"	"	"
-109	CLUTCH BLOCK PIN	"	"	"
-110	CLUTCH PIN	"	"	"
-111	FORM ROLLER GEAR	"	"	"
-112	COLLAR	"	"	"
5100	SPRING	"	"	"
-134	LOCK SCREW	"	"	"

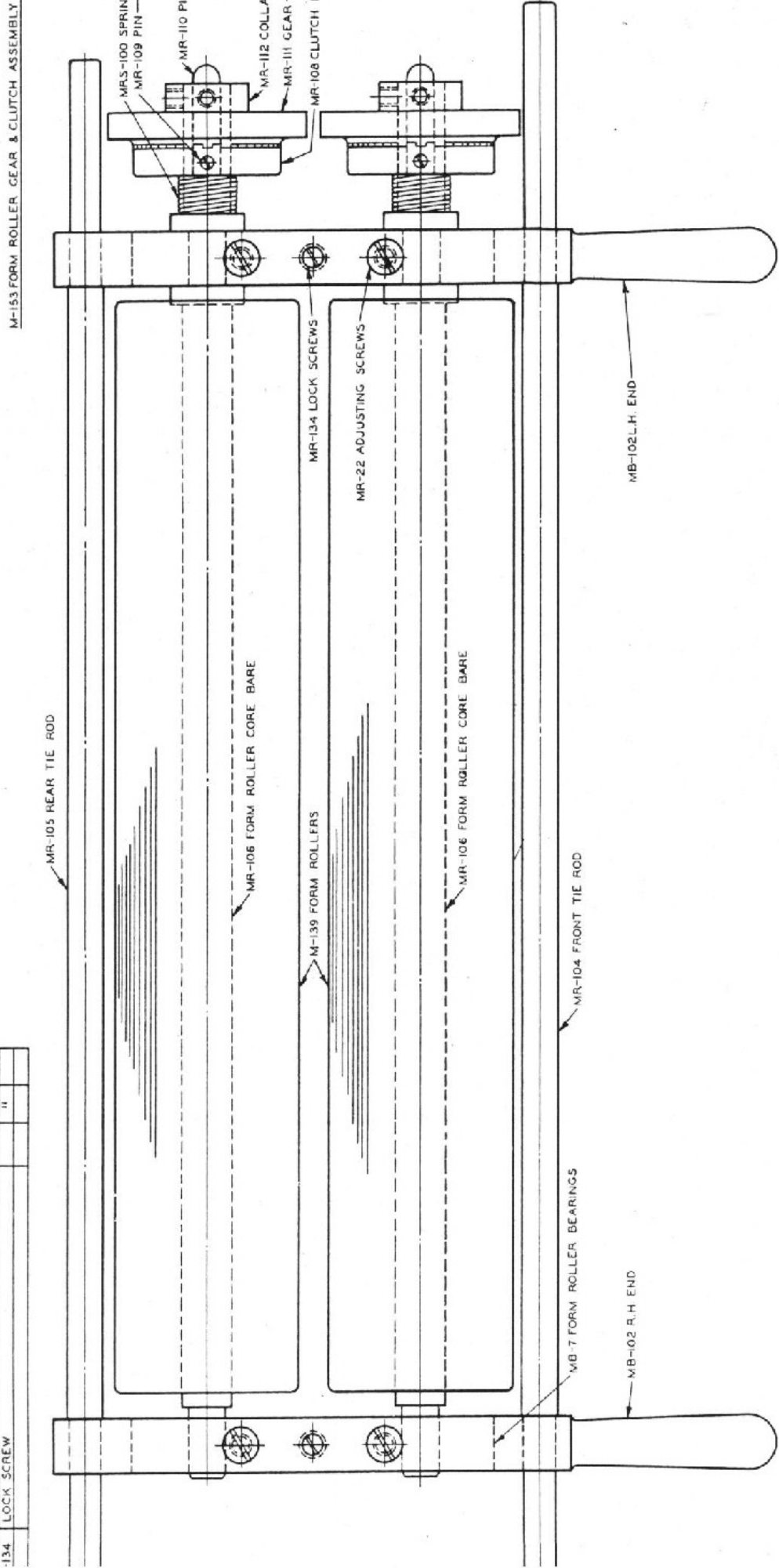

BOTTOM FRAME ASSEMBLY  
NO. 4 VANDERCOOK PROVING MACHINE

SHEET  
NO. 103

ART. NO.	PRICE	F. U.	L. U.
116		6369	
130		"	
135		"	
183		"	
B-101		"	
B-104		"	
B-105		"	
B-117		8938	
N-109		6369	
Z-5		"	
Z-43		"	
Z-53		"	
Z-54		"	
Z-59		"	
Z-66		"	
Z-100		"	
Z-101		"	
Z-103		"	
Z-112		"	
Z-114		"	
Z-115		"	
Z-116		"	
Z-117		9990	
Z-175		"	
Z-176		"	
Z-3		6369	
Z-6		"	
Z-102		"	
Z-102		"	
Z-106		"	
Z-116		"	
Z-117		"	
Z-122		"	
Z-125		"	
Z-150		"	
Z-157		"	
Z-254		8682	
Z-287		9990	
Z-3		6369	
Z-13		6369	
Z-29		"	
Z-43		"	
Z-134		"	
Z-135		"	
Z-13		"	
Z-161		"	
Z-37		6369	
Z-51		"	
Z-43		"	
Z-172		9990	
Z-4		6369	
Z-7		"	
Z-2		6369	
Z-126		9990	
Z-22		6369	
Z-30		9990	
Z-68		6369	

**LUBRICATION**

S.A.E. #20 MOTOR OIL IS RECOMMENDED FOR ALL MOVING PARTS. NOTE OIL HOLES IN CYLINDER BEARING MS-102 AND ONE HOLE IN EACH CYLINDER CARRIAGE PLATE/ALSO HOLES IN TRIP BRACKET MS-112. ALL BALL BEARINGS ARE PACKED IN GREASE AND REQUIRE NO FURTHER ATTENTION. A LIGHT FILM OF OIL SHOULD BE KEPT ON THE SURFACE OF IMPRESSION WHEELS AT ALL TIMES.

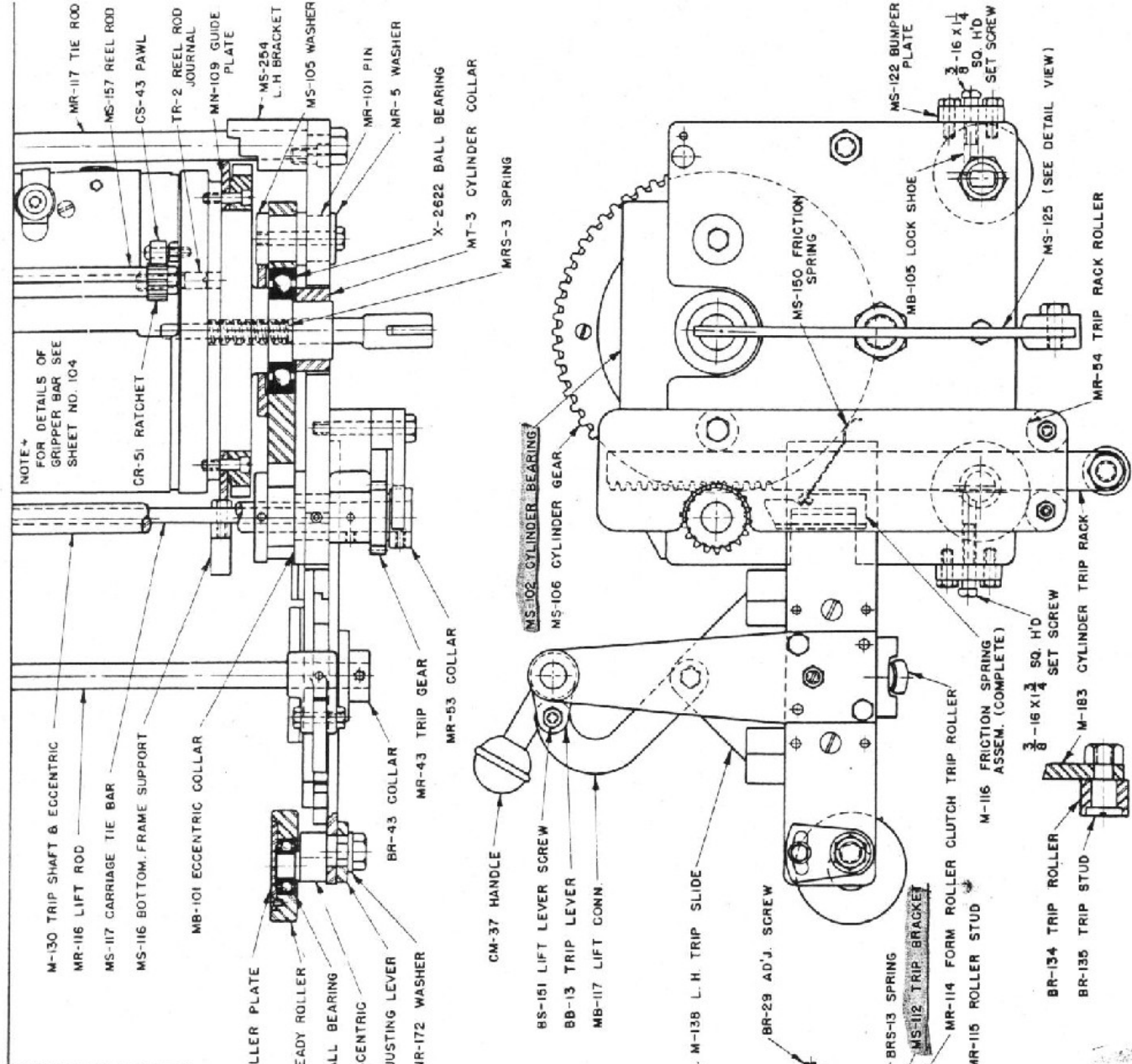

**CYLINDER CARRIAGE**







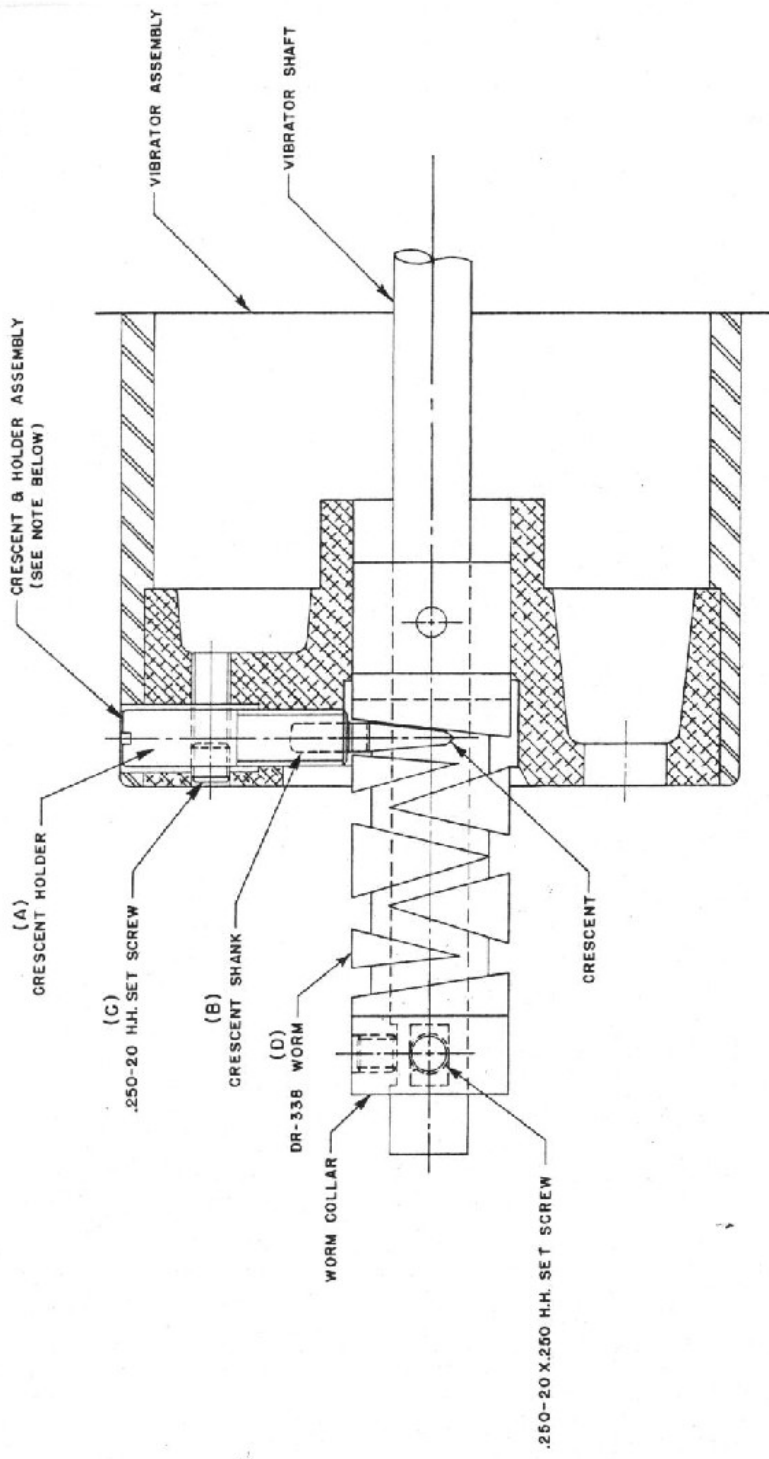

PARTIAL SECTION VIEW OF INK DRUM VIBRATOR ASSEMBLY

- ① ADJUST CRESCENT HOLDER-(A) UNTIL IT TOUCHES END OF CRESCENT SHANK-(B). THEN BACK OFF 3/4 OF A TURN AND LOCK HOLDER WITH .250-20 H.H. SET SCREW-(C). THIS SETTING MUST ALLOW WORM-(D) TO ROTATE FREE OF ANY DRAG, TRAVELING FULL LENGTH BOTH DIRECTIONS.
- ② COAT VIBRATOR WORM WITH GRAPHITE GREASE OR VASELINE.

NOTE - CRESCENT AND HOLDER ASSEMBLY AS SHOWN IS PART NO. M-184. THE ABOVE INSTRUCTIONS APPLY ALSO TO X-2031 CRESCENT AND HOLDER ASSEMBLY (NOT SHOWN).

CRESCENT OR WORM REPLACEMENT INSTRUCTIONS

VIEW SHOWING SIDE  
OPPOSITE GEARS

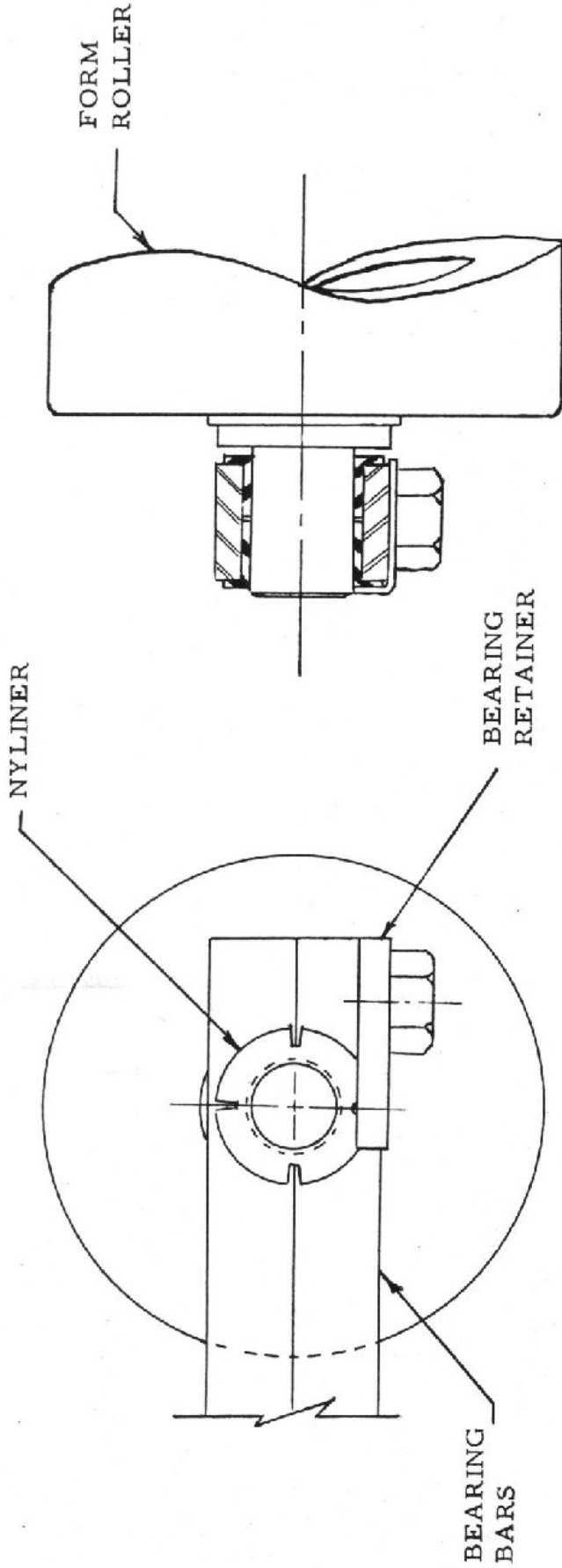

INSTALLATION INSTRUCTIONS

- 1 - REMOVE BOTTOM HALF OF BEARING BAR.
- 2 - APPLY NYLINERS TO CORE BEARING DIA.
  - (A) 4 NYLINERS ARE REQUIRED PER BEARING BAR. 8 PER MACHINE. 2 BEARING RETAINERS ARE USED ON OPPOSITE GEAR SIDE. (RETAINERS ARE NECESSARY TO HOLD NYLINERS IN PLACE.)
  - (B) ON GEAR SIDE, NYLINERS CAN BE INSERTED BY SPREADING APART & SLIPPING ON SHAFT. ON OPPOSITE GEAR SIDE, SLIDE NYLINERS ON BEARING DIA.
- 3 - REPLACE BOTTOM HALF OF BEARING BAR
  - (A) BEFORE REPLACING HEX HEAD SCREWS TO BEARING BARS ON OPPOSITE GEAR SIDE, SLIP BOLT THRU RETAINER, THEN TIGHTEN.
  - 4 - LUBRICATION - WHEN NYLINERS ARE BEING INSTALLED, LUBRICATE WITH S. A. E. #40 MOTOR OIL.